

# XAG P100 2022

Pilot's Maintenance Guide - LNT Mode

Version AU V1.0 **EN**

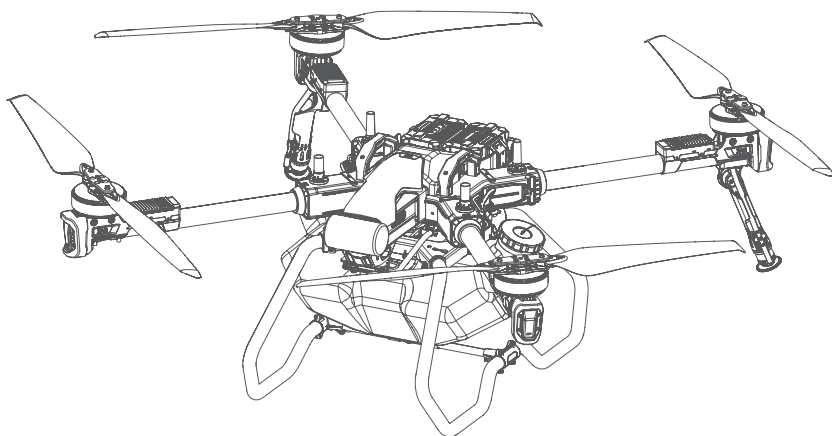

# MAINTENANCE GUIDE

---

Visit - [Know Your Drone](#) - for a safe and responsible flight

During the life cycle of the equipment, there will be wear and tear, and cases of malfunction. Regular and properly conducted maintenance can ensure that equipment is kept in the best optimal conditions for future operation, reducing failures and improving efficiency. (Every 100 Flights or after flying for over 20 hours)

Failure to conduct regular maintenance may result in serious injury to yourself and/or others, damage to your Products and/or other objects in the vicinity, and voiding the Manufacturer Warranty.

The proper maintenance of the equipment is specified as follows:

## Airframe Structure

01. Check and ensure there are no loose or missing screws on the Airframe Structure.
02. Check and ensure all components is conducted according to the manufacturer torque settings requirement.
03. Check and ensure the Landing skid, Airframe Structure, Airframe Arm, Antenna, Motor are firmly secured.
04. Check and ensure the electrical connection plug of all components are firmly secured and there are no signs of oxidation.
05. Check and ensure the equipment power socket and battery socket are clean and dry, and the sockets are not damaged or deformed.
06. Inspect and ensure the fuselage, Liquid tank and its components have no damages, cracks or deformities.
07. Inspect and ensure there are no deformation or damages on the beam structure of the side beam, and all the connection fasteners between the Arm and the motor are firmly secured.
08. Inspect and ensure there are no damages or deformation on the Airframe Arms, and ensure there are no abnormal angel of the sticker on the Airframe Arm to the Airframe Arm.
09. Check and ensure the radar modules are Clean and in good Condition (Not cracked, chipped, sunken, misshapen, or obstructed). Otherwise, obstacle avoidance or terrain following may result in serious injury to yourself and/or others, and damage to your Products and/or other objects in the vicinity.
10. Conduct regular Deep cleaning of the Aircraft, particularly the areas that are difficult to clean during the routine cleaning after flight operation. E.g., Interface of the Liquid Tank, or the Battery socket of the Equipment.

# Propulsion

- Propeller

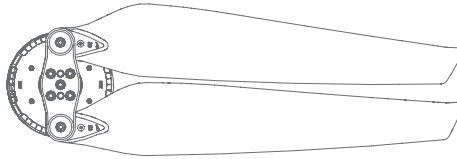

01. Inspect and ensure the Propeller Spinner have no damages, cracks or deformation.
02. Check and ensure the Propeller is not loose, softened, damaged or deformed.
03. Check and ensure the Propeller and the Propeller Spinner are properly tightened.
04. Check and ensure there are no missing or loose screws between the Propeller Spinner and the Motor. All fixing screws should be accounted and firmly secured.
05. Wringing a wet rag, then clean and remove any stains or foreign objects on the Propeller.

- Motor

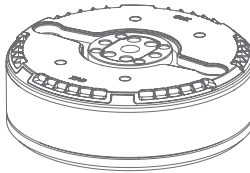

01. Remove the Propeller and Motor housing, then clean the Motor with a Compressed Air Duster.
02. Rotate the Motor to check the motor bearing for any abnormality, vibration or abnormal noise.
03. Inspect the Motor enamelled wire and ensure there are no damage or fracture.
04. Sway the Motor and ensure the Motor and Motor mount are firmly secured.
05. Check and ensure the wiring connector between the Motor and the ESC are firmly secured.

- ESC

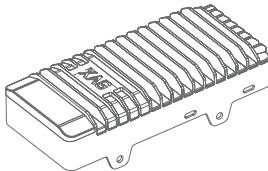

01. Check and ensure the ESC have no deformation or oxidation.
02. Check and ensure the ESC are firmly secured, and there are no loose or missing screws.
03. Check and ensure there are no pesticides or other foreign objects attached on the ESC's heat dissipation.

# Power System

- Battery

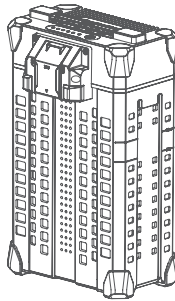

01. Handle the Battery with care
02. Wringing a wet rag, then wipe and clean the exterior of the batteries to remove any stains and foreign objects.
03. If the batteries are less than 10% (1 Green Flash), batteries must be recharged before storage. The battery may be damaged and not useable in the future if it is not charged before storage.
04. DO NOT charge the batteries in humid or wet environment.
05. DO NOT leave the battery in excessive heat or cold environments as it can reduce battery life, overheating the battery may lead to fire or an explosion.
06. DO NOT use the battery if the battery is leaking, bulged, deformed or damaged in appearance.
07. DO NOT disassemble the Battery without XAG's authorization.
08. DO NOT insert or remove the battery while the battery is turned on, otherwise the equipment's power socket and the battery socket may be damaged.
09. Batteries must to be charged every 2 months to 40%~60% for long-term storage.

- Power Socket

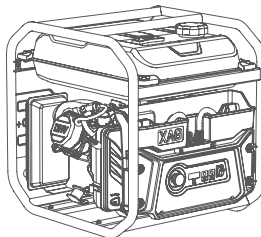

Dust, liquid, or other foreign objects adhere to the power socket may lead to short circuiting or sparks and damage the equipment (Battery, Charger, Internal Circuit, Power Socket and etc..). During the use of the equipment, user should systematically check and clean the power sockets of all equipment, and ensure the sockets are kept clean, dry, free of foreign objects and no deformation.

# XAG<sup>®</sup> RevoSpray 2

Spray system calibration (with clean water) should be conducted on a regular basis as the use of corrosive liquid and viscous liquid during the daily operation or replacement of peristaltic pump may lead to excessive deviation.

After the calibration is completed, inspect and ensure the health index is normal (1.2-1.4). If the health index remains abnormal after calibration, check and ensure the Peristaltic pump tubes and Spray Tubes are not shrivelled, deformed or lost its elasticity. Replace tubing if any of the above symptoms are found.

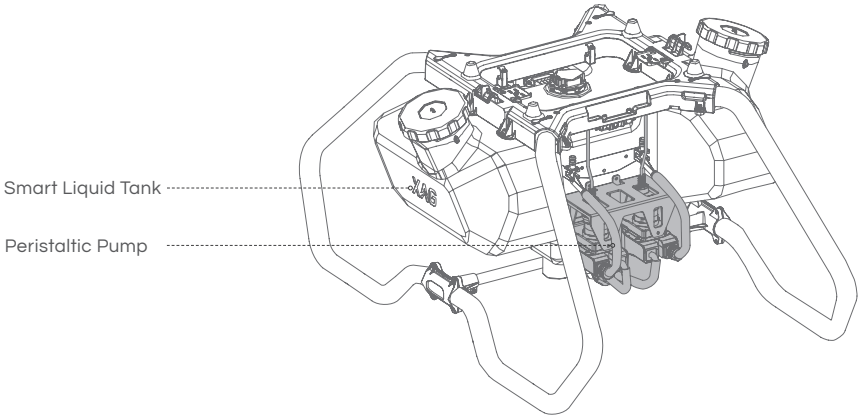

- **Liquid Tank**

01. Check and ensure the sealing ring of the liquid inlet are intact.
02. Unscrew the Cap, then check and ensure the inner tubes are in good condition.
03. Unscrew the filter and ensure the filter are kept clean, free of foreign objects and no deformation.

- **Peristaltic Pump**

01. Disassemble the Peristaltic pump and ensure the peristaltic pump tube and the roller are sufficiently lubricated. Apply Vaseline if the lubrication is poor.
02. Check and ensure the cable connectors on the Pump Controller Board are firmly secured, and there is no oxidation, and etc.

# XAG® RevoCast 2

To ensure the operational efficiency of the RevoCast Spreading system, it is necessary to conduct regularly cleaning and maintenance to ensure accurate measurement, and prevention of foreign objects attaching, entangling, or material jamming.

## Cleaning:

01. Disconnect the Spreader signal cable
02. Unfasten the Hasp securing the Quick release Unit, and extract the Quick release Unit from the RevoCast System.
03. Use clean or soap water to rinse the residual material remaining in the Quick release Unit and place it in a cool place to dry.

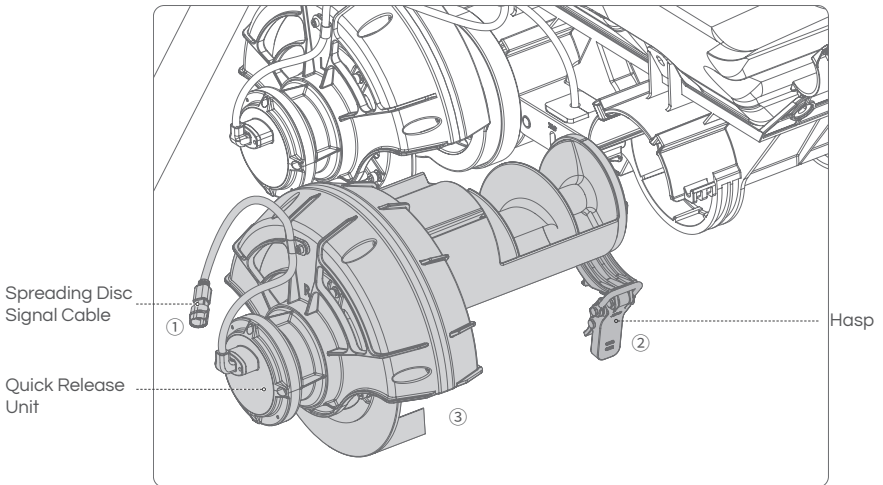

04. Open both container covers and use clean or soap water to rinse the residual material remaining within the container, then place it in a cool place to dry.

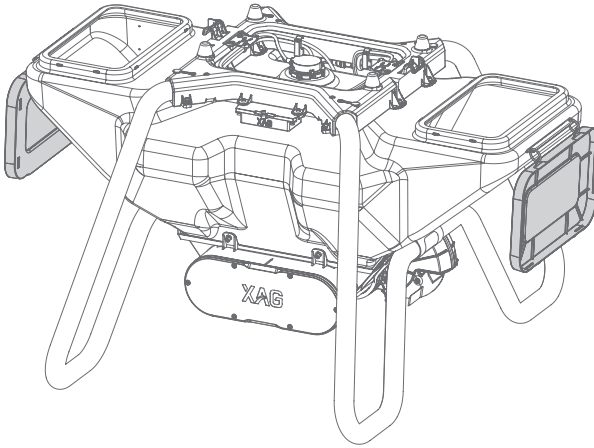

- Maintenance of Screw conveyor

01. Conduct regular inspection of the Screw conveyor, the screw conveyor will need to be replaced if the wear and tear on a single side exceed 2mm (Original diameter: 79mm)
02. Check and ensure the Cross Slot of the Screw conveyor are kept clean and free of foreign objects.

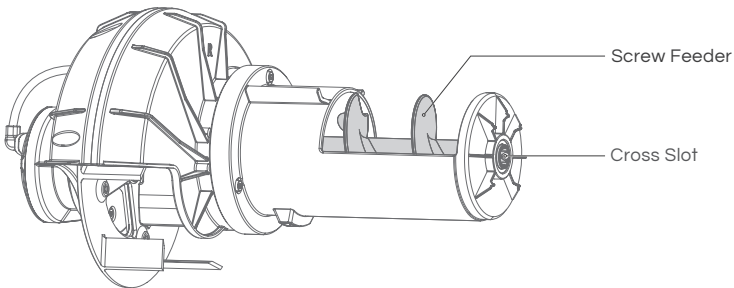

## • Maintenance of Quick release Unit

01. Check and ensure the Cross Slot and the round tube surface of the Quick release Unit are kept clean and free of foreign objects.
02. Check and ensure the Cross Axle and Guide Rail of the RevoCast System are kept clean and free of foreign objects.
03. Align the Round tube protruding strip of the Quick release Unit with the Guide Rail, then gently insert the Screw conveyor parallel to the RevoCast System.
04. Adjust the angle of the Screw conveyor through the feeding port of the Material container, matching the Cross Axle of the RevoCast to the Cross Slot of the Quick release Unit.
05. When the Quick release Unit is properly inserted, close and lock the Hasp and ensure the Quick release Unit is firmly secured.
06. Connect the Spreader signal cable, then affix the cable to the cable holder.

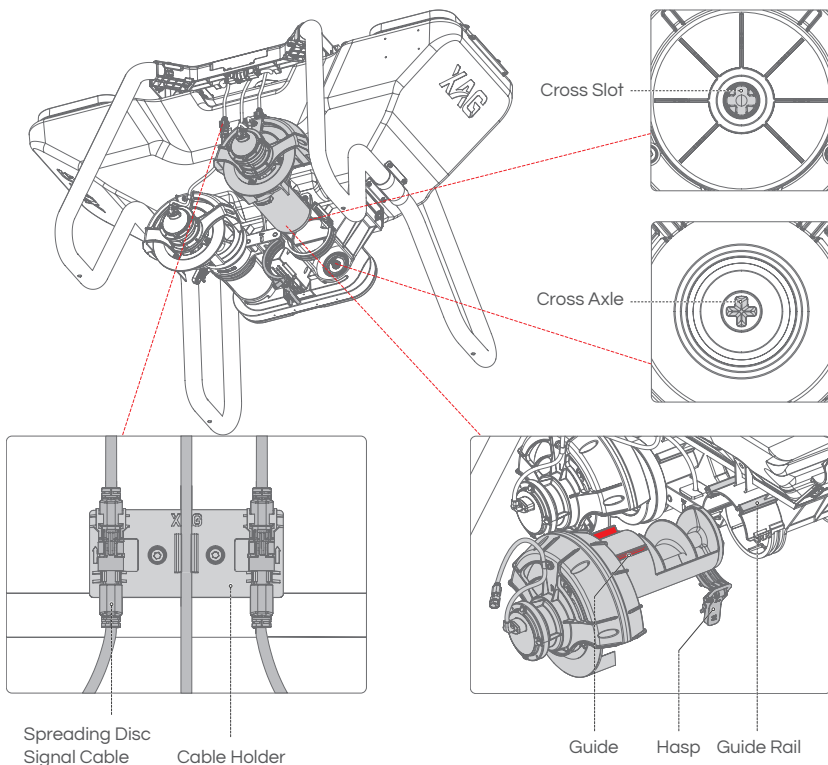

### IMPORTANT

- When inserting the Quick release Unit, please check and ensure the corresponding Unit is installed accordingly. Left and Right are indicated by the "L" and "R".
- If there are difficulty in closing and locking the Hasps, please do not use force as the Quick release Unit may be inserted incorrectly. Please remove the Quick release Unit and reassembled it again.



# EQUIPMENT STORAGE

---

Liquids and residues must be drained from the aircraft prior to storage, residues remaining within the spray system may cause liquid damage to the critical module.

Equipment should be stored in a dry environment within the temperature range of 10°C to 30°C.

Equipment should NOT be stored in a moist environment or where there is water leakage.



Moist environment



Water leakage

## Equipment with Lithium Battery

In addition to smart batteries, any equipment containing lithium batteries, such as ACS2 remote controller, RTK Battery Extension Rod, and other equipment must to be charged every 2 months to 40%-60% for storage when not in use for a long time.

# TRANSPORTATION MANAGEMENT

---

01. When transporting the Aircraft via vehicle, the propellers need to be folded and fixed with the Propeller Holder.

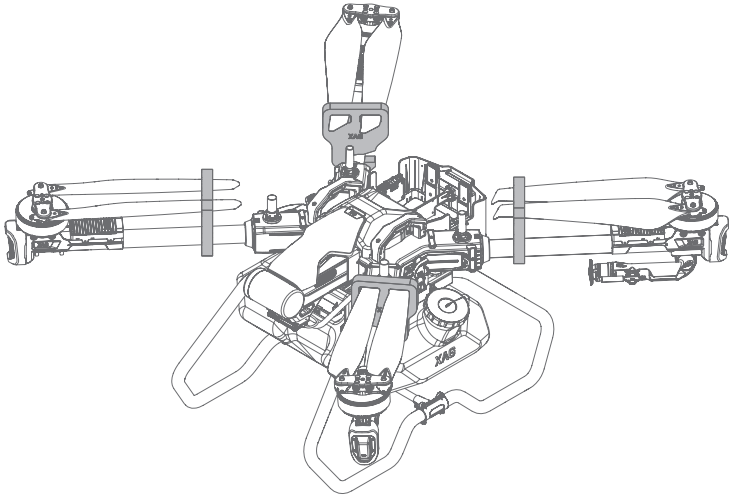

 **IMPORTANT**

- Liquids and residues must be drained from the aircraft prior to transportation, liquids or residues remaining within the spray system during transportation may cause damage to the critical module.
- Batteries must be removed from the Aircraft prior to any Transportation.
- Damages or Hardware failure causes by incorrect transportation method will be the user's sole responsibility.

02. Then firmly secure the aircraft with the airframe mounting brackets.

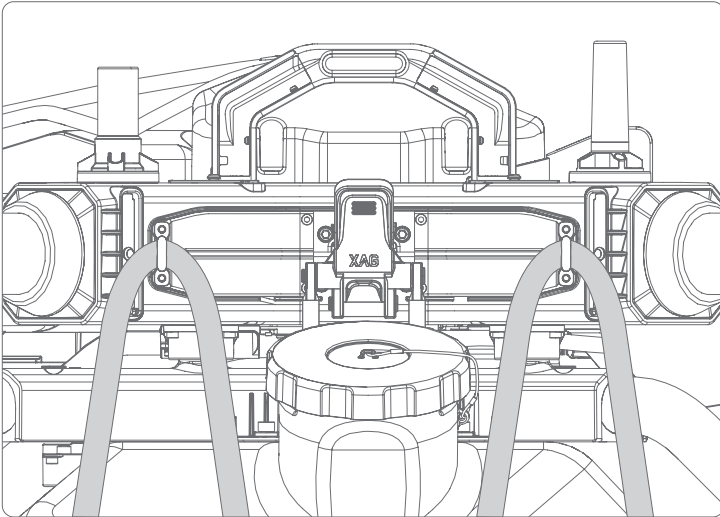

**Warning**

Do not drive fatigued, and the equipment should be kept and stored away from the occupant. Maintain air circulation and avoid pesticides inhalation.

# TECHNICAL SPECIFICATIONS

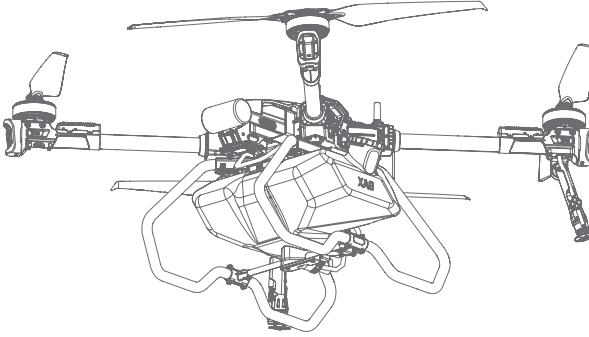

## P100 Agricultural RPA

Product Model	3WWDZ-40AH
Flight Control System	SuperX4 Pro
IP Rating	IPX7
Arm Material	Glass Fibre + Carbon Fibre Composite

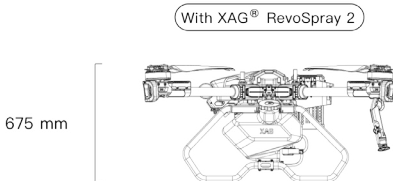
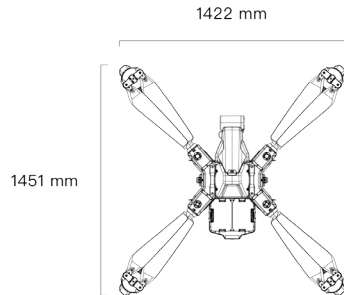
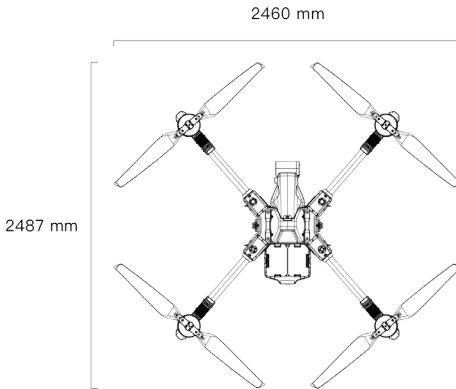

## Flight Parameters

Total Weight (No Module + Battery)	39.60 Kg
Empty Weight (Empty Container + Battery)	48.00 Kg (With RevoSpray Module) 53.00 Kg (With RevoCast Module)
Max Take-off Weight (Full Container + Battery)	88.00 Kg (With RevoSpray Module) 93.00 Kg (With RevoCast Module)
Max. Thrust-Weight Ratio	1.8
Load Ratio	0.45
Operating Frequency	SRRC: 2.4000GHz – 2.4835GHz
Transmission Power (EIRP)	2.4GHz SRRC: 20 dBm
Hovering Accuracy Range (With Strong GNSS Signal)	RTK Enabled: ±10cm (Horizontal) ±10cm (Vertical) RTK Disabled: ±0.6m (Horizontal) ±0.3m (Vertical)
RTK / GNSS Operating Frequency	GPS: L1/L2 GLONASS: L1/L2 BDS: B1/B2 Galileo: E1/E5b
Operating Frequency	2.4GHz / 5.8GHz
Sustainable High Precision Navigation with RTK Delay	≤600s
Hovering Time <sup>[2]</sup>	17 min (Take-Off weight of 48Kg @20000mAh x 2) 7min (Take-Off weight of 88Kg @20000mAh x 2)
Max. Operating Speed	13.8m/s (With Good GNSS Signal)
Max. Flying Height	30m
Max. Flying Distance	2000m
Max Service Ceiling Above Sea Level <sup>[3]</sup>	4000m
Recommended Operating Temperature	-10°C to 40°C

# Propulsion System

Motors	
Model	A45
Stator Size	136mm x 27mm
Max Power	4000W / Motor
Max Tension	45KG / Motor
KV Value	78RPM / V
ESCs	
Model	VC13200
Max Working Current (Continuous)	200A
Max Operating Voltage	56.4V
Foldable Propellers	
Model	P4718
Diameter x Pitch	47 x 18 inch
Weight	280g per Blade
Gross Weight	760g

# PSL Camera

Model	RD24412
Dimensions	70mm x 40mm x 25mm
Voltage	24V – 60V
Resolutions	720P / 1080P
Frame Rate	30fps
Coding Format	H.264
Focal Length	3.2mm
Image Sensor	1/2.9-inch CMOS Sensor

# Obstacle Sensor & Avoidance System

4D Imaging Radar <sup>[1]</sup>	
Model	RD24412
Operating Frequency	24 GHz
Voltage	24V – 60V
Power Consumption	6.5W
Sensing Range	1.5m ~ 40m
Sensing Mode	Millimetre-wave Imaging, MIMO
Sensing Parameters	Obstacle's Position, Distance, Relative Speed
Field of View (FOV)	Horizontal: $\pm 40^\circ$ Vertical: $-45^\circ$ to $90^\circ$
Safety Limit Distance	2.5m (Distance between the propeller tip and the obstacles after braking and hovering)
Working Conditions	Relative Height: $\geq 1.5\text{m}$ Relative Speed: $\leq 8\text{m/s}$

Terrain Sensor	
Model	TR24S100
Voltage	12V
Power	1.5W
Sensing Mode	Millimeter-wave
Operating Frequency	24GHz
Altitude detection range	0.5~100m (Relative Height from Vegetation)
Fixed Height Range	1 ~ 30m (Relative Height from Vegetation)
Max. Gradient	$45^\circ$ (Flight Speed $\leq 2\text{m/s}$ )

[1] Effectiveness of the Obstacle radar is dependent on the obstacle's material, location, distance, shape, size, relative velocity, etc.

[2] Hovering time acquired at sea level with wind speeds lower than 3m/s

[3] Maximum load needs to be reduced by 12% for each additional 1,000 m in altitude

# RevoSpray System

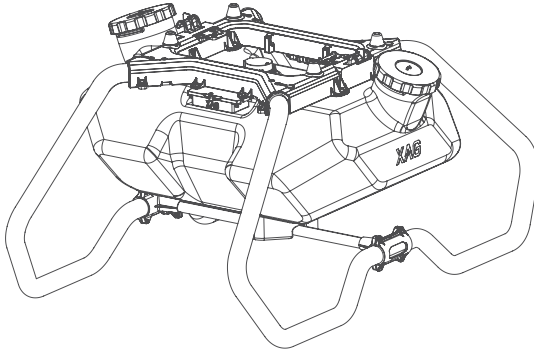

Liquid Tank	
Model	M4TANP40A
Material	PE
Volume	40L
Dimension	947.5mm x 734.5mm x 472 mm
Sensor	Liquid Level Sensor
Nozzle	
Nozzle Type	Centrifugal
Quantity	2
Rotational speed of Spray disc	1000RPM – 16000RPM
Spray Swath	5m – 10m
Droplet Size	60µm – 400µm
Peristaltic Pump	
Quantity	2
Voltage	50V
Max Flow Rate	6L/min (Single Pump) 12L/ min (Both Pump)



# RevoCast System

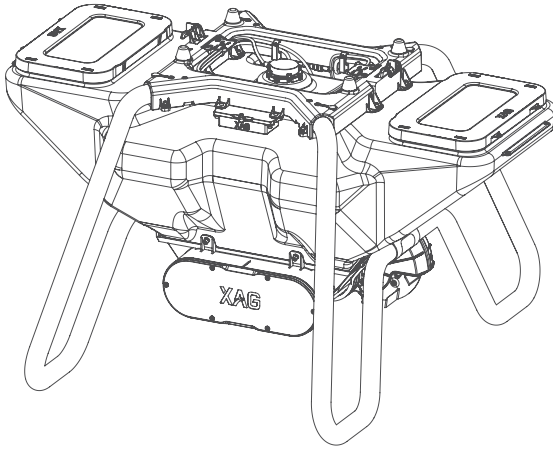

Model	M4RC-60B-P
Dimension	983mm x 873mm x 573mm
Net Weight	13.00Kg
Rated Capacity	60L
Rated Load	40Kg
Optimal Operating Temperature	0° C to 40° C
Storage Temperature	0° C to 40° C
IP Rating	IP65
Applicable granule Size	1-6mm (Dry Solid Granule)

## Local Network Terminal

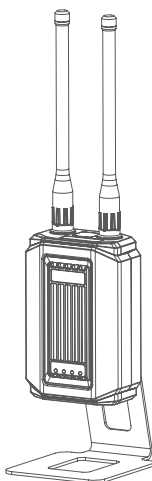

### Local Network Terminal

Model	13LNT-1
Dimensions	93mm x 54mm x 332mm
Weight	Approx. 760g
Power Input	DC 12V/3A
Operating Temperature	0° C to 50° C
IP Rating	IP54
Communication Protocol	Wi-Fi
Operating Frequency	2400 – 2483.5 MHz
Antenna	TNC Port, 2dBi
Warranty Details	12 Months

### Power Adapter

Dimensions	101mm x 86mm x 37mm
Weight	Approx. 335g
Power Input	DC 40 – 54V (B13960S Battery Adaptor)
Power Output	DC 12V/3A
Power	36W
Operating Temperature	0° C to 50° C
IP Rating	IP54

## Remote Controller

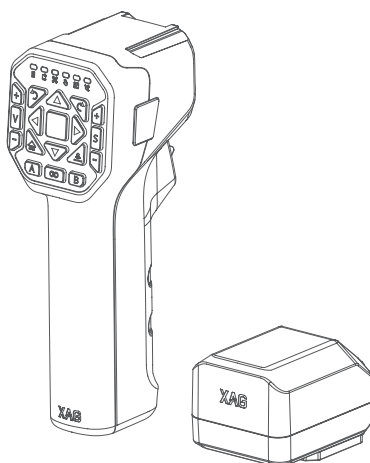

Model	ACS2G	
Dimensions	76mm x 60mm x 177mm	
IP Rating	IP54	
Operating Frequency	2.4GHz / 5.8GHz	
Transmitting Power (EIRP)	2.4GHz	SRRC ≤ 20dBm;
	5.8GHz	SRRC ≤ 26dBm;
Supported Operating System	Android, IOS	
Build-in Battery	5000mAh / 37Wh	
Charging Temperature	0° C to 45° C	
Operating Temperature	-20° C to 55° C	
	-20° C to 20° C	< 1 Month
	-20° C to 45° C	1 – 3 Months
Storage Temperature	-20° C to 55° C	3 – 12 Months
Max Transmission Distance (Unobstructed, free of interference)	800 Meters	
Charging Voltage / Current	05V / 2A	
	09V / 1.5A	
	12V / 1.5A	
Mesh Network	Supported	
Voice Broadcast	Supported	
RTK Operating Frequency	GPS:	L1/L2
	GLONASS:	L1/L2
	BDS:	B1/B2
	Galileo:	E1/E5b
Positioning Accuracy (With strong RTK Signal)	Vertical:	< 5.0cm + 1ppm (RMS)
	Horizontal:	< 7.5cm + 1ppm (RMS)
Warranty Details	12 Months	

# Smart Battery

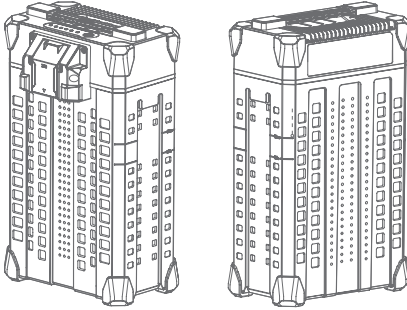

Model	B13960S
Dimensions	189mm x 139mm x 317mm
Weight	Approx. 6.7 kg
Battery Type	Lithium Polymer
Capacity	20000 m/Ah
Energy	962 Wh
Rated Output	48.1V / 120A
Operating Temperature	10° C to 45° C
Charging Temperature	10° C to 40° C
Storage Temperature	10° C to 30° C
IP Rating	IP65
Compatible Aircraft	XAG V40 2021 XAG P40 2021 XAG P100 2022
Compatible Chargers	CM12500P GC4000+
Charging Voltage	56.55V
Battery Charging Time	
Warranty Details	6 Months

# Battery Charger

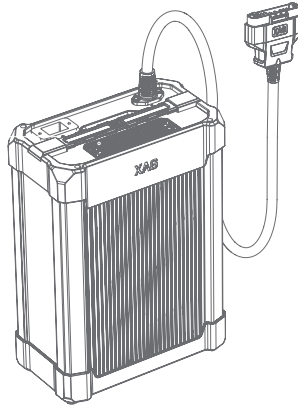

Model	CM12500P
Compatible Battery	B13960S B13860S (With Plug A1 Adapter)
Dimensions	242mm x 137mm x 337mm
Weight	Approx. 9.0 kg
Operating Temperature	-10° C to 45° C
Storage Temperature	-20° C to 55° C
Cooling Mode	Outer Air Cooling
Operating Altitude	≤ 3000m
Input	AC 90-165V ~ 50/60Hz 23A (Max) AC 180-260V ~ 50/60Hz 23A (Max)
Output	DC 50-60V/25A (Max) / 1250W (AC 90-165V ~ 50/60Hz) DC 50-60V/50A (Max) / 2550W (AC 180-260V ~ 50/60Hz)
Warranty Details	12 Months

# GNSS XRTK4 Mobile Station

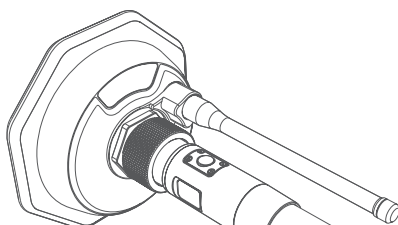

## RTK Positioning Module for Agricultural Use

Model	XRTK4
Dimensions (Diameter x Height)	154mm x 83.6mm (RTK Module) 154mm x 1230mm (RTK Module + Rod)
Weight	1.5 Kg (RTK Module)
Port/Panel	Button x 3, Positioning Indicator x 1 Networking Indicator x 1, Power Indicator x 1
IP Rating	IP65
Operating Temperature	-20° C to 60° C
Storage Temperature	-20° C to 60° C
Relative Humidity	100%, condensation
Warranty Details	12 Months

## GNSS Performance & Specifications

Compatible motherboard	K726
GNSS Frequency	
BDS	B1I / B2I / B3I / B1C / B2a
GPS	L1 / L2 / L5
GLONASS	L1, L2, L2C,
Galileo	E1 / E5a / E5b
QZSS	L1 / L2 / L5
RTK Positioning Accuracy	
Horizontal	±10mm+1ppm (RMS)
Vertical	±15mm+1ppm (RMS)
Initialization time	Typical <10 seconds
Initialization Reliability	>99.9%
Data update rate	Maximum 20 Hz (Raw data) Maximum 20 Hz (Positioning data)

## Communication Interface

1 CAN port;

3 mobile communication modules (2G/3G/4G);

1 dedicated 2.4GHz/5.8GHz WLAN.

## Communication

Mobile communication network

Communication modules 2G/3G/4G

Protocols GSM, CDMA2000/EVDO, WCDMA,  
TD-SCDMA, LTE-FDD, LTE-TDD

Dedicated 2.4GHz/5.8GHz WLAN

Protocol supported Xlink Communication Protocol

Transmission performance Frequency range 2.400-2.4835GHz/5.735-5.835GHz

Channel spacing 20 MHz

Frequency error/ frequency stability  $\pm 10$  ppm

Communication mode Full duplex

Communication protocol Transparent

Forward error correction FEC

Data rate 6Mbps

Modulation OFDM

Emission performance RF output power Less than 1W  
Subject to regional SRRC/FCC/CE standards

Reception performance Decoding sensitivity -90dbm

## External Hardware Interface

Battery terminal  $\times 1$

SIM card slot  $\times 3$

## Battery Extension Rod

Model B4100

Dimensions (Diameter x Height) 45mm x 1166mm

Capacity 7500mAh 99Wh

Input 12.0 V/1 A (Type-C port)

Output 14.4V/1A

Operating temperature  $-10^{\circ}\text{C}$  to  $45^{\circ}\text{C}$

Port/Panel Power Button  $\times 1$ , Type-C Port  $\times 1$ ,  
Battery Level/Status Display Panel  $\times 1$

Warranty Details 6 Months



---

Copyright©2022 XAG Australia All Rights Reserved

The copyright of all information in this user manual (including but not limited to any text description, illustrations, photos, methods, processes, etc.) belongs to XAG Australia and is protected by copyright law. No individual or organization may imitate, extract, translate, distribute or reproduce or quote all the contents of this manual without any written authorization.